

# **8875 Skid-Steer Loader**

## **TECHNICAL MANUAL**

**John Deere  
Lawn & Grounds Care Division  
TM1566 (Feb 95)**

This technical manual is written for an experienced technician and contains sections that are specifically for this product. It is a part of a total product support program.

The manual is organized so that all the information on a particular system is kept together. The order of grouping is as follows:

- Table of Contents
- Specifications
- Theory of Operation
- Troubleshooting Diagram
- Diagnostics
- Tests & Adjustments
- Repair

*Note: Depending on the particular section or system being covered, not all of the above groups may be used.*

Each section will be identified with a symbol rather than a number. The groups and pages within a section will be consecutively numbered.

All information, illustrations and specifications in this manual are based on the latest information available at the time of publication. The right is reserved to make changes at any time without notice.

We appreciate your input on this manual. To help, there are postage paid post cards included at the back. If you find any errors or want to comment on the layout of the manual please fill out one of the cards and mail it back to us.

**Safety**



**Specifications and Information**



**Engine (Diesel)**



**Electrical**



**Power Train**



**Power Train (Hydrostatic)**



**Steering**



**Brakes**



**Hydraulics**



**Backhoe**



**Miscellaneous**



COPYRIGHT® 1995  
JOHN DEERE HORICON WORKS  
Horicon, Wisconsin  
All rights reserved

## SAFETY

---



### HANDLE FLUIDS SAFELY-AVOID FIRES

- BE PREPARED FOR EMERGENCIES



TS291

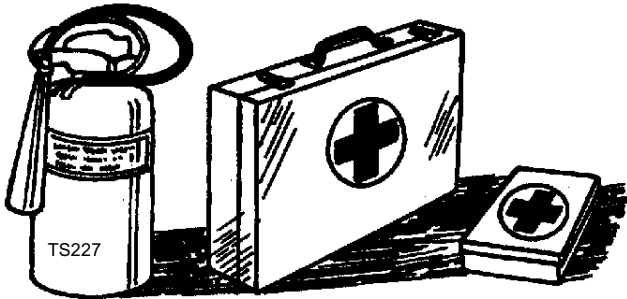

TS227

When you work around fuel, do not smoke or work near heaters or other fire hazards.

Store flammable fluids away from fire hazards. Do not incinerate or puncture pressurized containers.

Make sure machine is clean of trash, grease, and debris.

Do not store oily rags; they can ignite and burn spontaneously.

Be prepared if a fire starts.

Keep a first aid kit and fire extinguisher handy.

Keep emergency numbers for doctors, ambulance service, hospital, and fire department near your telephone.

### HANDLE CHEMICAL PRODUCTS SAFELY



TS1132

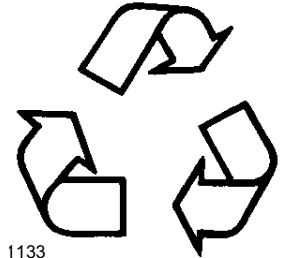

1133

Direct exposure to hazardous chemicals can cause serious injury. Potentially hazardous chemicals used with John Deere equipment include such items as lubricants, coolants, paints, and adhesives.

A Material Safety Data Sheet (MSDS) provides specific details on chemical products: physical and health hazards, safety procedures, and emergency response techniques. Check the MSDS before you start any job using a hazardous chemical. That way you will know exactly what the risks are and how to do the job safely. Then follow procedures and recommended equipment.

- DISPOSE OF WASTE PROPERLY

Improperly disposing of waste can threaten the environment and ecology. Potentially harmful waste used with John Deere equipment include such items as oil, fuel, coolant, brake fluid, filters, and batteries. Use leakproof containers when draining fluids. Do not use food or beverage containers that may mislead someone into drinking from them. Do not pour waste onto the ground, down a drain, or into any water source. Inquire on the proper way to recycle or dispose of waste from your local environmental or recycling center, or from your John Deere dealer.

**Thanks very much for your reading,  
Want to get more information,  
Please click here, Then get the complete  
manual**

**JustClickHere** 

**NOTE:**

**If there is no response to click on the link above,  
please download the PDF document first, and then  
click on it.**

**Have any questions please write to me:  
[admin@servicemanualperfect.com](mailto:admin@servicemanualperfect.com)**

## USE CARE AROUND HIGH-PRESSURE FLUID LINES

### • AVOID HIGH-PRESSURE FLUIDS

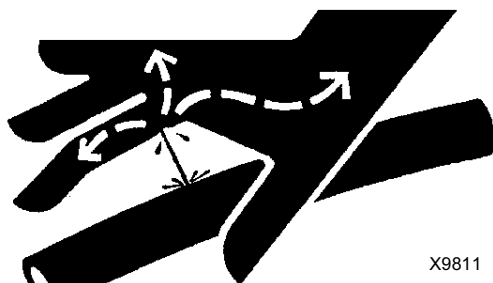

X9811

Escaping fluid under pressure can penetrate the skin causing serious injury.

Avoid the hazard by relieving pressure before disconnecting hydraulic or other lines. Tighten all connections before applying pressure.

Search for leaks with a piece of cardboard. Protect hands and body from high pressure fluids.

If an accident occurs, see a doctor immediately. Any fluid injected into the skin must be surgically removed within a few hours or gangrene may result. Doctors unfamiliar with this type of injury should reference a knowledgeable medical source. Such information is available from Deere & Company Medical Department in Moline, Illinois, U.S.A.

### • AVOID HEATING NEAR PRESSURIZED FLUID LINES



TS953

Flammable spray can be generated by heating near pressurized fluid lines, resulting in severe burns to yourself and bystanders. Do not heat by welding, soldering, or using a torch near pressurized fluid lines or other flammable materials. Pressurized lines can be accidentally cut when heat goes beyond the immediate flame area.

## USE CARE IN HANDLING AND SERVICING BATTERIES

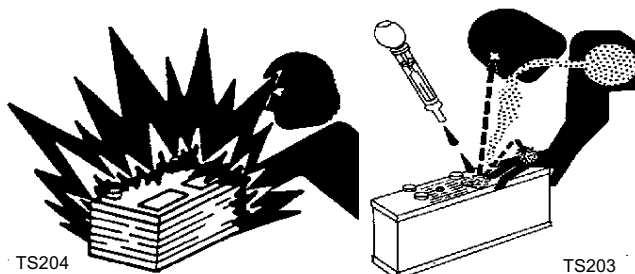

TS204

TS203

### • PREVENT BATTERY EXPLOSIONS

- Keep sparks, lighted matches, and open flame away from the top of battery. Battery gas can explode.
- Never check battery charge by placing a metal object across the posts. Use a voltmeter or hydrometer.
- Do not charge a frozen battery; it may explode. Warm battery to 16°C (60°F).

### • PREVENT ACID BURNS

- Sulfuric acid in battery electrolyte is poisonous. It is strong enough to burn skin, eat holes in clothing, and cause blindness if splashed into eyes.

### • Avoid acid burns by:

1. Filling batteries in a well-ventilated area.
2. Wearing eye protection and rubber gloves.
3. Avoiding breathing fumes when electrolyte is added.
4. Avoiding spilling or dripping electrolyte.
5. Use proper jump start procedure.

### • If you spill acid on yourself:

1. Flush your skin with water.
2. Apply baking soda or lime to help neutralize the acid.
3. Flush your eyes with water for 10\_15 minutes.
4. Get medical attention immediately.

### • If acid is swallowed:

1. Drink large amounts of water or milk.
2. Then drink milk of magnesia, beaten eggs, or vegetable oil.
3. Get medical attention immediately.

# SAFETY



## USE SAFE SERVICE PROCEDURES

### • WEAR PROTECTIVE CLOTHING

Wear close fitting clothing and safety equipment appropriate to the job.

Prolonged exposure to loud noise can cause impairment or loss of hearing. Wear a suitable hearing protective device such as earmuffs or earplugs to protect against objectionable or uncomfortable loud noises.

Operating equipment safely requires the full attention of the operator. Do not wear radio or music headphones while operating machine.

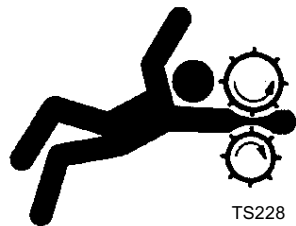
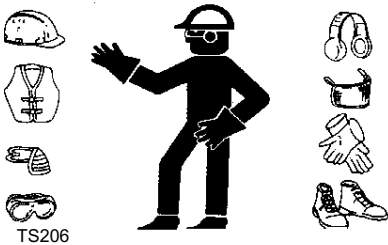

### • SERVICE MACHINES SAFELY

Tie long hair behind your head. Do not wear a necktie, scarf, loose clothing, or necklace when you work near machine tools or moving parts. If these items were to get caught, severe injury could result.

Remove rings and other jewelry to prevent electrical shorts and entanglement in moving parts.

### • USE PROPER TOOLS

Use tools appropriate to the work. Makeshift tools and procedures can create safety hazards. Use power tools only to loosen threaded parts and fasteners. For loosening and tightening hardware, use the correct size tools. **DO NOT** use U.S. measurement tools on metric fasteners. Avoid bodily injury caused by slipping wrenches. Use only service parts meeting John Deere specifications.

### • PARK MACHINE SAFELY

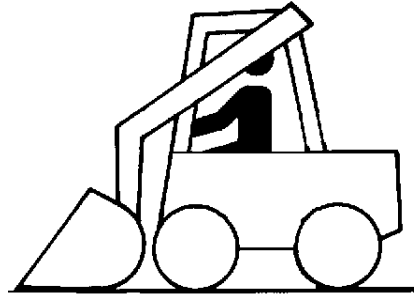

#### • Before working on the machine:

1. Lower all equipment to the ground.
2. Stop the engine and remove the key.
3. Disconnect the battery ground strap.
4. Hang a "DO NOT OPERATE" tag in operator station.

### • SUPPORT MACHINE PROPERLY AND USE PROPER LIFTING EQUIPMENT

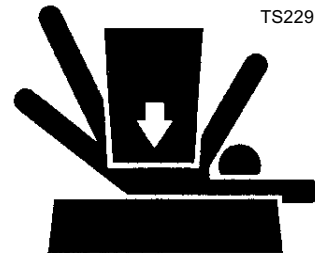

If you must work on a lifted machine or attachment, securely support the machine or attachment.

Do not support the machine on cinder blocks, hollow tiles, or props that may crumble under continuous load. Do not work under a machine that is supported solely by a jack. Follow recommended procedures in this manual.

Lifting heavy components incorrectly can cause severe injury or machine damage. Follow recommended procedure for removal and installation of components in the manual.

- **WORK IN CLEAN AREA**

- **BEFORE STARTING A JOB**

1. Clean work area and machine:
2. Make sure you have all necessary tools to do your job.
3. Have the right parts on hand.
4. Read all instructions thoroughly; do not attempt shortcuts.

- **ILLUMINATE WORK AREA SAFELY**

Illuminate your work area adequately but safely. Use a portable safety light for working inside or under the machine. Make sure the bulb is enclosed by a wire cage. The hot filament of an accidentally broken bulb can ignite spilled fuel or oil.

- **WORK IN VENTILATED AREA**

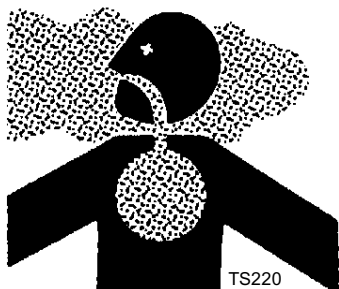

TS220

Engine exhaust fumes can cause sickness or death. If it is necessary to run an engine in an enclosed area, remove the exhaust fumes from the area with an exhaust pipe extension.

If you do not have an exhaust pipe extension, open the doors and get outside air into the area.

- **REMOVE PAINT BEFORE WELDING OR HEATING**

Avoid potentially toxic fumes and dust. Hazardous fumes can be generated when paint is heated by welding, soldering, or using a torch. Do all work outside or in a well ventilated area. Dispose of paint and solvent properly. Remove paint before welding or heating: If you sand or grind paint, avoid breathing the dust. Wear an approved respirator. If you use solvent or paint stripper, remove stripper with soap and water before welding. Remove solvent or paint stripper containers and other flammable material from area. Allow fumes to disperse at least 15 minutes before welding or heating.

- **DISCONNECT ELECTRONIC INSTRUMENT PANEL MODULE (EIPM) BEFORE WELDING OR BATTERY CHARGING**



Before welding, battery charging, or using any high voltage equipment which attaches to the Skid Steer Loader, always disconnect the Electronic Instrument Panel Module connector from the back of the electronic board. This will prevent high voltage surges which can erase the memory stored in the electronic chips of the EIPM.

- **AVOID HARMFUL ASBESTOS DUST**

Avoid breathing dust that may be generated when handling components containing asbestos fibers. Inhaled asbestos fibers may cause lung cancer.

Components in products that may contain asbestos fibers are brake pads, brake band and lining assemblies, clutch plates, and some gaskets. The asbestos used in these components is usually found in a resin or sealed in some way. Normal handling is not hazardous as long as airborne dust containing asbestos is not generated.

Avoid creating dust. Never use compressed air for cleaning. Avoid brushing or grinding material containing asbestos. When servicing, wear an approved respirator. A special vacuum cleaner is recommended to clean asbestos. If not available, apply a mist of oil or water on the material containing asbestos. Keep bystanders away from the area.

- **SERVICE TIRES SAFELY**



TS95Z

Explosive separation of a tire and rim parts can cause serious injury or death.

Do not attempt to mount a tire unless you have the proper equipment and experience to perform the job. Always maintain the correct tire pressure. Do not inflate the tires above the recommended pressure. Never weld or heat a wheel and tire assembly. The heat can cause an increase in air pressure resulting in a tire explosion. Welding can structurally weaken or deform the wheel.

When inflating tires, use a clip-on chuck and extension hose long enough to allow you to stand to one side and NOT in front of or over the tire assembly. Use a safety cage if available.

## SAFETY

---



- Check wheels for low pressure, cuts, bubbles, damaged rims or missing lug bolts and nuts.

## LIVE WITH SAFETY

TS231

### REPLACE SAFETY SIGNS

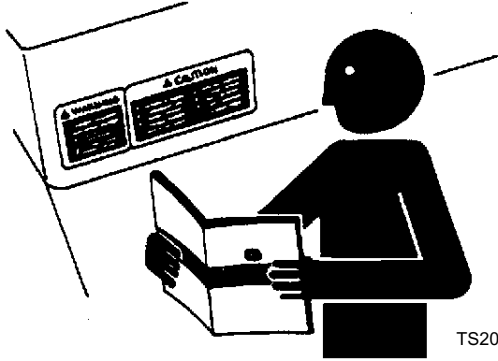

TS201

Replace missing or damaged safety signs. See the machine operator's manual for correct safety sign placement.



Before returning machine to customer, make sure machine is functioning properly, especially the safety systems. Install all guards and shields.



# CONTENTS

	Page
<b>GENERAL VEHICLE SPECIFICATIONS</b> .....	<b>2</b>
<b>UNIFIED INCH TORQUE VALUES</b> .....	<b>4</b>
<b>METRIC TORQUE VALUES</b> .....	<b>5</b>
<b>DIESEL FUEL SPECIFICATIONS</b> .....	<b>6</b>
DIESEL FUEL STORAGE .....	6
<b>LUBRICANT SPECIFICATIONS</b> .....	<b>7</b>
ENGINE OIL .....	7
GREASE .....	7
TRANSMISSION AND HYDRAULIC OIL .....	8
CHAIN CASE OIL .....	8
GEARBOX OIL .....	8
ALTERNATIVE LUBRICANTS .....	8
SYNTHETIC LUBRICANTS .....	8
OIL FILTERS .....	8
LUBRICANT STORAGE .....	8
ENGINE COOLANT .....	8
<b>SERIAL NUMBER LOCATION</b> .....	<b>10</b>
SKID STEER LOADER PRODUCT IDENTIFICATION NUMBER .....	10
ENGINE SERIAL NUMBER .....	10



**GENERAL VEHICLE SPECIFICATIONS**













	<b>8875</b>
<b>ENGINE</b>	
Make	John Deere
Model	3029T
Type	Diesel
Cylinders	3
Bore	106.4 mm (4.19 in.)
Stroke	111.5 mm (4.39 in.)
Displacement	2.9 L (177 cu. in.)
Compression ratio	18:1
Net horsepower	45.5 kW (61)
RPM, slow (no load)	950
RPM, fast (no load)	2270
Lubrication	Force-feed; Pressurized with flow filter.
Crankcase capacity (with filter)	8.5 L (9 qt.)
Cooling system	Liquid
Coolant capacity	15.1 L (16 qt.)
Air filter type	2-Stage, replaceable paper element
<b>ELECTRICAL</b>	
Type of starter	Delco Remy 28MT
Battery voltage	12 V
Battery reserve capacity at 27°C (80° F)	160 minutes
Battery cold cranking amps at -18°C (0°F)	925 amps
Charging system	55 amp Magneton alternator
<b>FUEL SYSTEM</b>	
Fuel	Diesel # 1 or # 2
Capacity	71.2 L (18.8 gal)
Fuel delivery	Inline direct injection
Fuel shut-off	Internal Fuel shutoff solenoid in Injection Pump
<b>POWER TRAIN</b>	
Type	Hydrostatic
Charge pump	Internal gerotor type in R/H Hydrostatic pump
Hydrostatic pumps	Variable displacement axial piston

	8875
Hydrostatic pump relief pressure	34473 kPa (5000 psi)
Hydrostatic motor	Variable displacement axial piston
Charge relief pressure	2068 kPa (300 psi)
Chain case capacity (each side)	7.6 L (2 gal.)
Gearbox capacity (each gearbox)	2.8 L (3 qt.)
Brakes	Dual disks on hydrostatic motor shaft
<b>STEERING</b>	
Type	Power - hydrostatic
<b>PERFORMANCE</b>	
Manufacturers operating load	568 kg (1250 lb.)
Hydraulic lift capacity	998 kg (2200 lb.)
Ground speed (low range—high range)	12.2—19.6 km/h (7.5—12.0 mph)
Operating weight	3025 kg (6670 lb.)
<b>HYDRAULICS</b>	
Main system relief pressure	17927 kPa (2600 psi)
Circuit relief pressure	18961 kPa (2750 psi)
Hydraulic valve	3 spool open center
<b>DIMENSIONS</b>	
Length less bucket	2845 mm (112 in.)
Length with bucket	3607 mm (142 in.)
Width less bucket	1753 (69 in.)
Height to ROPS	1829 mm (72 in.)
Height to hinge pin	3099 mm (122 in.)
Dump height	2464 mm (97 in.)
Dump reach	762 mm (30 in.)
Dump angle	45°
Bucket rollback	37°
Wheelbase	1219 mm (48 in.)
Ground clearance	203 mm (8 in.)
Angle of departure	28°



UNIFIED INCH TORQUE VALUES



SAE Grade and Head Markings	1 or 2 <sup>b</sup> No Marks 	5  5.1  5.2 	8  8.2 
	2 No Marks 	5  	8  

SIZE	Grade 1		Grade 2 <sup>b</sup>		Grade 5, 5.1 or 5.2		Grade 8 or 8.2	
	Lubricated <sup>a</sup>	Dry <sup>a</sup>	Lubricated <sup>a</sup>	Dry <sup>a</sup>	Lubricated <sup>a</sup>	Dry <sup>a</sup>	Lubricated <sup>a</sup>	Dry <sup>a</sup>
	Nm	lb-ft	Nm	lb-ft	Nm	lb-ft	Nm	lb-ft
1/4	3.7	2.8	4.7	3.5	6	4.5	7.5	5.5
5/16	7.7	5.5	10	7	12	9	15	11
3/8	14	10	17	13	22	16	27	20
7/16	22	16	28	20	35	26	44	32
1/2	33	25	42	31	53	39	67	50
9/16	48	36	60	45	75	56	95	70
5/8	67	50	85	62	105	78	135	100
3/4	120	87	150	110	190	140	240	175
7/8	190	140	240	175	190	140	240	175
1	290	210	360	270	290	210	360	270
1-1/8	470	300	510	375	470	300	510	375
1-1/4	570	425	725	530	570	425	725	530
1-3/8	750	550	950	700	750	550	950	700
1-1/2	1000	725	1250	925	990	725	1250	930

DO NOT use these values if a different torque value or tightening procedure is given for a specific application. Torque values listed are for general use only. Check tightness of fasteners periodically.

Shear bolts are designed to fail under predetermined loads. Always replace shear bolts with identical grade.



















Fasteners should be replaced with the same or higher grade. If higher grade fasteners are used, these should only be tightened to the strength of the original. Make sure fasteners threads are clean and that you properly start thread engagement. This will prevent them from failing when tightening. Tighten plastic insert or crimped steel-type lock nuts to approximately 50 percent of the dry torque shown in the chart, applied to the nut, not to the bolt head.

Tighten toothed or serrated-type lock nuts to the full torque value.

<sup>a</sup> "Lubricated" means coated with a lubricant such as engine oil, or fasteners with phosphate and oil coatings. "Dry" means plain or zinc plated without any lubrication<sup>b</sup>

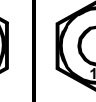
<sup>b</sup> Grade 2 applies for hex cap screws (not hex bolts) up to 152 mm (6-in.) long. Grade 1 applies for hex cap screws over 152 mm (6-in.) long, and for all other types of bolts and screws of any length.

METRIC TORQUE VALUES

Property Class and Head Markings	4.8		8.8		9.8		10.9		12.9	
										
Property Class and Nut Markings	5		10		10		10		12	
										



SIZE	Class 4.8				Class 8.8 or 9.8				Class 10.9				Class 12.9			
	Lubricated <sup>a</sup>		Dry <sup>a</sup>		Lubricated <sup>a</sup>		Dry <sup>a</sup>		Lubricated <sup>a</sup>		Dry <sup>a</sup>		Lubricated <sup>a</sup>		Dry <sup>a</sup>	
	Nm	lb-ft	Nm	lb-ft	Nm	lb-ft	Nm	lb-ft	Nm	lb-ft	Nm	lb-ft	Nm	lb-ft	Nm	lb-ft
M6	48	3.5	6	4.5	9	6.5	11	8.5	13	9.5	17	12	15	11.5	19	14.5
M8	12	8.5	15	11	22	16	28	20	32	24	40	30	37	28	47	35
M10	23	17	29	21	43	32	55	40	63	47	80	60	75	55	95	70
M12	40	29	50	37	75	55	95	70	110	80	140	105	130	95	165	120
M14	63	47	80	60	120	88	150	110	175	130	225	165	205	150	260	109
M16	100	73	125	92	190	140	240	175	275	200	350	225	320	240	400	300
M18	135	100	175	125	260	195	330	250	375	275	475	350	440	325	560	410
M20	190	140	240	180	375	275	475	350	530	400	675	500	625	460	800	580
M22	260	190	330	250	510	375	650	475	725	540	925	675	850	625	1075	800
M24	330	250	425	310	650	475	825	600	925	675	1150	850	1075	800	1350	1000
M27	490	360	625	450	950	700	1200	875	1350	1000	1700	1250	1600	1150	2000	1500
M30	675	490	850	625	1300	950	1650	1200	1850	1350	2300	1700	2150	1600	2700	2000
M33	900	675	1150	850	1750	1300	2200	1650	2500	1850	3150	2350	2900	2150	3700	2750
M36	1150	850	1450	1075	2250	1650	2850	2100	3200	2350	4050	3000	3750	2750	4750	3500

DO NOT use these values if a different torque value or tightening procedure is given for a specific application. Torque values listed are for general use only. Check tightness of fasteners periodically.

Shear bolts are designed to fail under predetermined loads. Always replace shear bolts with identical grade.

Fasteners should be replaced with the same or higher grade. If higher grade fasteners are used, these should only be tightened to the strength of the original. Make sure fasteners threads are clean and that you properly start thread engagement. This will prevent them from failing when tightening.

Tighten plastic insert or crimped steel-type lock nuts to approximately 50 percent of the dry torque shown in the chart, applied to the nut, not to the bolt head. Tighten toothed or serrated-type lock nuts to the full torque value.

<sup>a</sup> "Lubricated" means coated with a lubricant such as engine oil, or fasteners with phosphate and oil coatings. "Dry" means plain or zinc plated without any lubrication.

<sup>b</sup> Grade 2 applies for hex cap screws (not hex bolts) up to 152 mm (6-in.) long. Grade 1 applies for hex cap screws over 152 mm (6-in.) long, and for all other types of bolts and screws of any length.

**DIESEL FUEL SPECIFICATIONS**

Use only clean, high quality fuel.

Use Grade No. 2-D fuel at temperatures above 4°C (40°F).



Use Grade No. 1-D fuel at temperatures below 4°C (40°F).

Use Grade No. 1-D fuel for all air temperatures at altitudes above 1500 m (5000 ft).

**IMPORTANT: Use fuel with less than 1.0 per cent sulfur. If possible, use fuel with less than 0.5 per cent sulfur. If fuel sulfur is more than 0.5 per cent, change engine oil and filter every 100 hours.**

For maximum filter life, sediment and water should not be more than 0.10 per cent.

The octane number should be 40 minimum. If you operate your tractor where air temperatures are normally low or where altitudes are high, you may need fuel with a higher cetane number.

Cloud Point - For cold weather operation, cloud point should be 10°F (6°C) below lowest normal air temperature.

**Fuel Tank Capacity**

**8875 . . . . . 71.2 L (18.8 gal)**

**DIESEL FUEL STORAGE**

NOTE: Diesel fuels stored for a long time may form gum and plug filters.

Keep fuel in a clean container in a protected area. Water and sediment must be removed before fuel gets to the engine. Do not use de-icers to remove water from fuel. Do not depend on fuel filters to remove water. If possible, install a water separator at the storage tank outlet. (See your John Deere dealer for this part.)

**IMPORTANT: Keep all dirt, scale, water or other foreign material out of fuel.**

Store fuel drum on its side with plug up.

**DO NOT STORE DIESEL FUEL IN GALVANIZED CONTAINERS**

**IMPORTANT: Diesel fuel stored in galvanized containers reacts with the zinc coating of the container to form zinc flakes. If fuel contains any water, a zinc gel will also form. The gel and flakes will quickly plug fuel filters and may damage fuel injectors and fuel pumps.**

Store diesel fuel in:

- plastic containers
- aluminum containers
- specially coated steel containers made for diesel fuel.

**DO NOT USE BRASS-COATED CONTAINERS:** brass is an alloy of copper and zinc.

LUBRICANT SPECIFICATIONS

ENGINE OIL

Use oil viscosity based on the expected air temperature range during the period between oil changes.

The following oil is preferred:

- John Deere TORQ-GARD SUPREME PLUS-50™

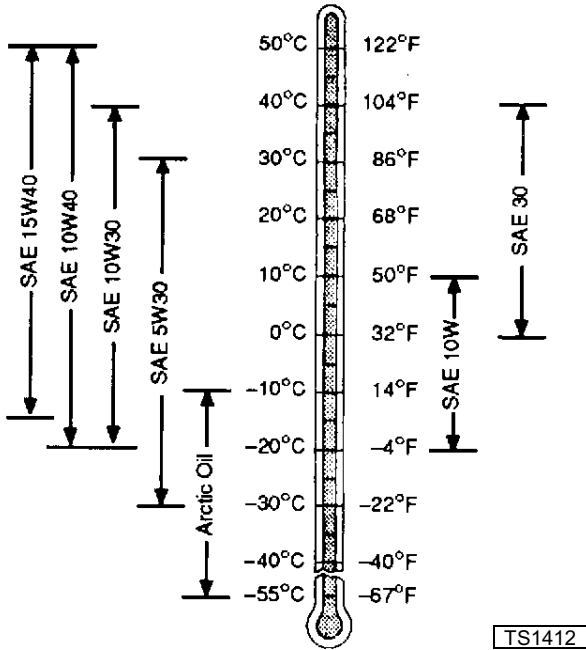

The following oils are also recommended:

- John Deere TORQ-GARD SUPREME®
  - John Deere UNI-GARD™
- Other oils may be used if they meet one of the following:
- API Service Classification CE
  - API Service Classification CD
  - CCMC Specification D5
  - CCMC Specification D4
  - Oils meeting Military Specification MIL-L-46167B may be used as arctic oils.

If John Deere TORQ-GARD SUPREME PLUS-50™ engine oil and a John Deere oil filter are used, the oil and filter service interval may be extended by 50 hours.

If diesel fuel exceeding 0.5% sulphur content is used, reduce the service interval for engine oil and filter by 50%.

GREASE

Use grease based on the expected air temperature range during the service interval.

The following greases are preferred:

- John Deere MOLY HIGH TEMPERATURE EP GREASE
- John Deere HIGH TEMPERATURE EP GREASE
- John Deere GREASE-GARD™

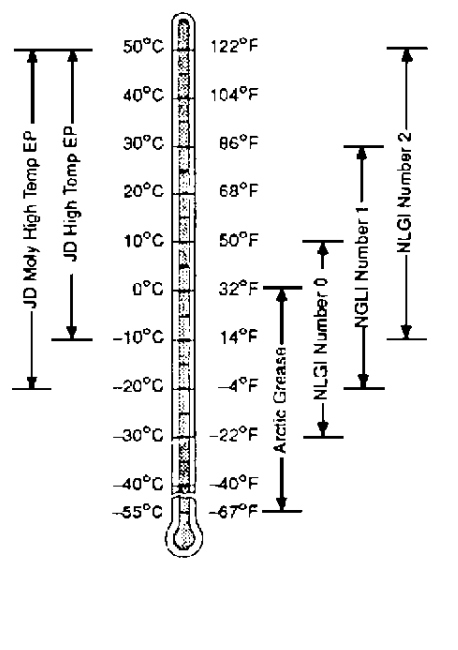

Other greases may be used if they meet one of the following:

- SAE Multipurpose EP Grease with a maximum of 5% molybdenum disulfide.
  - SAE Multipurpose EP Grease
- Greases meeting Military Specification MIL-G-10924F may be used as arctic grease.

**TRANSMISSION AND HYDRAULIC OIL**

The following oil is preferred:



- John Deere PLUS-4 ® 10W-30

When adding small amounts of oil to top off the oil reservoir, the following oil in descending order is permissible:

- John Deere TURF-GARD ®
- 10W-30 oil equivalent to John Deere PLUS-4 ®
- John Deere HY-GARD ®

**CHAIN CASE OIL**

The following oil is preferred:

- John Deere PLUS-4 ® 10W-30

When adding small amounts of oil to top off the oil reservoir, the following oil in descending order is permissible:

- John Deere TURF-GARD ®
- 10W-30 oil equivalent to John Deere PLUS-4 ®
- John Deere HY-GARD ®

**GEARBOX OIL**

Use oil viscosity based on the expected air temperature range during the period between oil changes.

John Deere GL-5 Gear Lubricant is recommended.

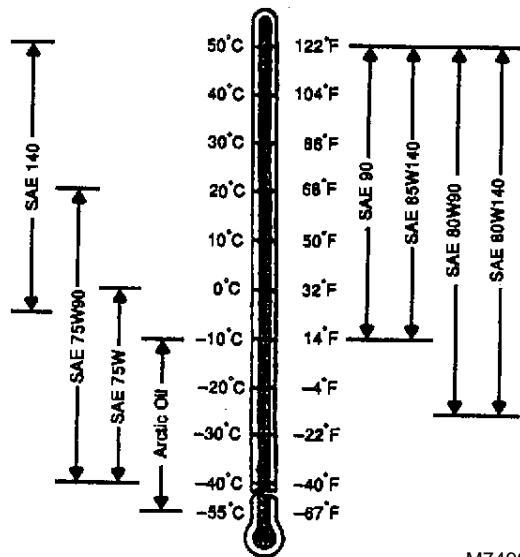

M74991

Other oils may be used if they meet one or more of the following:

- API Service Classification GL-5.
- Military Specification MIL-L-2105D.
- Military Specification MIL-L-2105C.

- Military Specification MIL-L-2105B.

Oils meeting Military Specification MIL-L-10324A may be used as arctic oils.

**ALTERNATIVE LUBRICANTS**

Conditions in certain geographical areas outside the United States and Canada may require different lubricant recommendations than these printed in this manual or the operator's manual. Consult with your John Deere Dealer, or Sales Branch to obtain the alternative lubricant recommendations.

**SYNTHETIC LUBRICANTS**

Synthetic lubricants may be used in John Deere equipment if they meet the applicable performance requirements (industry classification and/or military specification) as shown in this group.

The recommended temperature limits and service or oil change intervals should be maintained as shown in the operator's manual.

Avoid mixing different brands, grades, or types of oil. Oil manufacturers blend additive in their oils to meet certain specifications and performance requirements. Mixing different oils can interfere with the proper functioning of these additives and degrade lubricant performance.

**OIL FILTERS**

Filtration of oils is critical to proper lubrication. Always change filters regularly.

Use filters meeting John Deere performance specification.

**LUBRICANT STORAGE**

This machine can operate at top efficiency only if clean lubricants are used.

Use clean containers to handle all lubricants. Store them in an area protected from dust, moisture, and other contamination. Store drums on their sides.

**ENGINE COOLANT**

To meet cooling system protection requirements, the coolant MUST consist of a 50/50 mixture of quality water and ethylene glycol concentrate (antifreeze). Add to the mixture 3% (by volume) supplemental coolant additives (SCA's). See ENGINE COOLANT SPECIFICATIONS, later in this group, for further definition.

Makeup of the coolant between changes MUST consist of the same requirements as during a complete change. Performing a COOLSCAN analysis is the recommended method for determining the amount of